



Atmospheric Elevators

Atmospheric Robotic Components





HAtm-50 Atmospheric Elevators

Atmospheric Robotic Components

FEATURES

- High reliability of > 3 million MCBF
- Pay load up to 34kg
- Compact design including integrated controller
- RS-232 / Ethernet control interface
- CE/S2 compliant
- Class 1 cleanroom compatible
- Stroke 185mm and 305mm

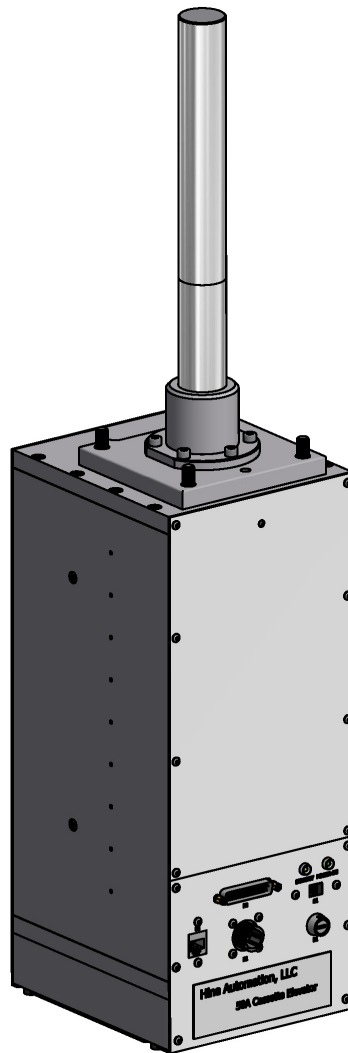

HAtm-50

Hine Automation's Elevators are the next generation Random Access Atmospheric Elevators. The HAtm-50 can be integrated into any cassette load port or process module requiring vertical motion. Thanks to its brushless DC motor and its proven design, Hine's Elevators provide precise substrate indexing capabilities. High strength undercarriage and precision guides allow Hine's elevators to be integrated in applications requiring handling of heavy payloads.



Atmospheric Elevators

Atmospheric Robotic Components

	HAtm-50
Wafer Sizes	User Defined†
Pay Load	34kg*
Mounting Configuration	Bottom
Axes of Motion	Z
Weight	27kg
Input Power	24 VDC at 2.5 Amps
Maximum Temperature	100°C
Exposed Materials	Stainless Steel 300 and 400 Series
Control Interface	RS-232 / Ethernet
MCBF	>3.00E+06
SEMI S2	compliant
CE	compliant
Repeatability	0.05mm‡
Vertical Stroke	185mm

† Head plates for SEMI standard wafer sizes up to 200mm available.

Custom substrate sizes available upon request.

* Higher payloads available upon request

‡ Measured as three standard deviations (3σ)



About Hine Automation

Hine Automation, LLC is a designer and manufacturer of automation systems and robotic components. We serve Original Equipment Manufacturers (OEMs) in the semiconductor, solar, flat panel display and related industries across the globe. Our robotic components satisfy a wide range of needs; from flexible research and development environments to stringent manufacturing environments. Combining our unsurpassed quality and reliability with modular and versatile designs to meet today's automation challenges, our products provide functional and economical solutions.

Our Mission

Our goal is to design and manufacture the most cost effective automation solutions and deliver unparalleled customer service and support.

Our Strengths

- Demonstrated Reliability
- Cost Effective Solutions
- Custom Solutions
- Lightning Speed Response and Turn-around Times
- Knowledge, Experience-driven Designs

Our Products

- **Cluster Systems:**
Constellation Systems
- **Automated Load Locks:**
Star Systems
- **Robotic Components:**
Vacuum Robotic Arms
Vacuum Elevators
Vacuum Aligners
Atmospheric Robotic Arms
Atmospheric Elevators
Atmospheric Aligners

